

# ICOM

**BISS 1200  
Compatible**

INSTRUCTION MANUAL

VHF TRANSCEIVER

# IC-F51

UHF TRANSCEIVER

# IC-F61

**CE0081** 

II 2G Ex ib II A T3 Gb  
II 2D Ex tb III C T160°C Db IP67  
(Tamb=-20°C to +55°C)

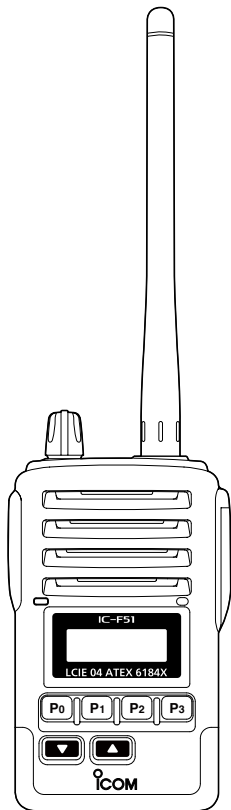

This illustration shows  
the IC-F51.

**icom Inc.**

---

# FOREWORD

---

**READ ALL INSTRUCTIONS** carefully and completely before using the transceiver.

**SAVE THIS INSTRUCTION MANUAL**— This instruction manual contains important operating instructions for the IC-F51 VHF TRANSCEIVER and IC-F61 UHF TRANSCEIVER.

/// This instruction manual includes some functions which are usable only when they are pre-programmed by your dealer. Ask your dealer for details.

---

## OPERATING NOTES

---

- When transmitting with a portable transceiver, hold the transceiver in a vertical position with its microphone 5 to 10 centimeters away from your mouth. Keep the antenna at least 2.5 centimeters from your head and body.
- If you wear a portable two-way radio on your body, ensure that the antenna is at least 2.5 centimeters from your body when transmitting.

---

# EXPLICIT DEFINITIONS

---

WORD	DEFINITION
<b>⚠ DANGER!</b>	Personal death, serious injury or an explosion may occur.
<b>⚠ WARNING!</b>	Personal injury, fire hazard or electric shock may occur.
<b>CAUTION</b>	Equipment damage may occur.
<b>NOTE</b>	If disregarded, inconvenience only. No risk of personal injury, fire or electric shock.

---

# INTRINSIC SAFETY

---



Versions of the IC-F51/F61 which display the “EX” marking on the serial number seal.

The approval rating for these models are II 2G Ex ib IIA T3 Gb and II 2D Ex tb IIIC T160°C Db IP67.

**WARNING! NEVER** charge the BP-227AXD (with/without the transceiver) in an explosive atmosphere. The optional battery chargers are not approved as Intrinsically Safe.

When the transceiver is used in a hazardous area, the BP-227AXD **MUST** be attached, either the jack cover or HM-138 **MUST** be attached to the speaker-microphone connector.

**KEEP** the transceiver and the BP-227AXD clean to avoid any risk of ignition due to the build-up of electrostatic charges.

Repair of Icom radios should only be carried out by authorized Icom distributors. In particular, repair of ATEX approved radios can **ONLY** be done by Icom to maintain the intrinsically safe rating. **NEVER** attempt to repair an ATEX approved radio. Only Icom has the repair expertise and procedures to maintain the ATEX approval. Contact your Icom distributor or authorised dealer for details.

The equipment can be used without the microphone but with the jack cover.

The ATEX standard is described on the 94/9/EC sticker (Ex Marking) and BP-227AXD as below.

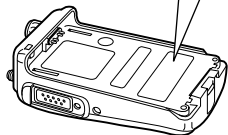

\* The following illustrations show the IC-F51/F61.

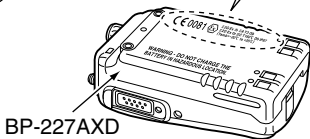

- DO NOT OPEN WHEN AN EXPLOSIVE ATMOSPHERE MAY BE PRESENT.
- DO NOT CHARGE THE BATTERY IN HAZARDOUS LOCATION.

---

# PRECAUTIONS

---

⚠ **DANGER! NEVER** short the terminals of the battery pack.

⚠ **DANGER!** Use and charge only specified Icom battery packs with Icom transceivers or Icom chargers. Only Icom battery packs are tested and approved for use with Icom radios or charged with Icom chargers. Using third-party or counterfeit battery packs or chargers may cause smoke, fire, or cause the battery to burst.

⚠ **WARNING! NEVER** hold the transceiver so that the antenna is very close to, or touching exposed parts of the body, especially the face or eyes, while transmitting. The transceiver will perform best if the microphone is 5 to 10 cm away from the lips and the transceiver is vertical.

⚠ **WARNING! NEVER** operate the transceiver with a headset or other audio accessories at high volume levels. Hearing experts advise against continuous high volume operation. If you experience a ringing in your ears, reduce the volume level or discontinue use.

**CAUTION: NEVER** connect the transceiver to a power source other than the BP-227AXD. Such a connection will ruin the transceiver.

**CAUTION: MAKE SURE** the flexible antenna and battery pack are securely attached to the transceiver, and that the antenna and battery pack are dry before attachment. Exposing the inside of the transceiver to water will result in serious damage to the transceiver.

**DO NOT** push the PTT when not actually desiring to transmit.

---

---

**DO NOT** use or place the transceiver in direct sunlight or in areas with temperatures below  $-20^{\circ}\text{C}$  or above  $+55^{\circ}\text{C}$ .

The basic operations, transmission and reception of the transceiver, are guaranteed within the specified operating temperature range. However, the LCD display may not operate correctly, or show an indication in the case of long hours of operation, or after being placed in extremely cold areas.

**DO NOT** modify the transceiver. The transceiver warranty does not cover any problems caused by unauthorized modification.

**DO NOT** use harsh solvents such as benzene or alcohol when cleaning, as they will damage the transceiver surfaces.

**BE CAREFUL!** The transceiver will become hot when operating it continuously for long periods of time.

**BE CAREFUL!** The transceiver meets IP67\* requirements for dust-tight and waterproof protection. However, once the transceiver has been dropped, dust-tight and waterproof protection cannot be guaranteed because of possible damage to the transceiver's case or the waterproof seal.

\* Only when the battery pack and jack cover are attached.

**MAKE SURE** to turn the transceiver power OFF before connecting the supplied/optional equipment.

**MAKE SURE** the flexible antenna and battery pack are securely attached to the transceiver, and that the antenna and battery pack are dry before attachment. Exposing the inside of the transceiver to water will result in serious damage to the transceiver.

---

# TABLE OF CONTENTS

---

FOREWORD .....	i
OPERATING NOTES.....	i
EXPLICIT DEFINITIONS.....	ii
INTRINSIC SAFETY.....	iii
PRECAUTIONS.....	v
TABLE OF CONTENTS.....	vii
SUPPLIED ACCESSORIES.....	viii
<b>1 ACCESSORIES .....</b>	<b>1–2</b>
■ Accessory attachments .....	1
<b>2 PANEL DESCRIPTION.....</b>	<b>3–11</b>
■ Front, top and side panels .....	3
■ Function display.....	6
■ Programmable function keys .....	7
<b>3 CONVENTIONAL OPERATION.....</b>	<b>12–18</b>
■ Turning power ON.....	12
■ Channel selection .....	12
■ Call procedure .....	13
■ Receiving and transmitting .....	14
■ Scrambler function.....	17
■ User Set mode.....	18
<b>4 BIIS OPERATION .....</b>	<b>19–34</b>
■ Default setting.....	19
■ Receiving a call.....	20
■ Transmitting a call .....	23
■ Receiving a message .....	26
■ Transmitting a status .....	29
■ Transmitting an SDM.....	30
■ Position data transmission.....	31
■ Printer connection.....	32
■ PC connection .....	32
■ Digital ANI.....	32



■ Auto emergency transmission .....	33
■ Stun function.....	33
■ BIIS indication.....	34
■ Priority A channel selection .....	34
<b>5 BATTERY CHARGING .....</b>	<b>35–44</b>
■ Caution .....	35
■ Optional battery chargers .....	39
<b>6 SPEAKER-MICROPHONE .....</b>	<b>45–46</b>
■ Optional HM-138 description .....	45
■ Attachment.....	46
<b>7 OPTIONS .....</b>	<b>47–48</b>
<b>8 ATEX CAUTIONS.....</b>	<b>49–51</b>
<b>9 CE .....</b>	<b>52–53</b>

---

## SUPPLIED ACCESSORIES

---

The following accessories are supplied:	Qty.
• Flexible antenna.....	1
• Battery pack .....	1
• Jack cover .....	1 set
• Belt clip .....	1 set
• Function name stickers* (KEY-STICKER).....	1

\*There are no names on the programmable function keys since the functions can be freely assigned to [P0] to [P3], [Red], [▼] and [▲] keys. Attach the supplied function name stickers above the appropriate keys for easy recognition of that key's assigned function.

# 1 ACCESSORIES

## ■ Accessory attachments

### ◇ Flexible antenna

Connect the supplied flexible antenna to the antenna connector.

#### CAUTION:

- **NEVER** carry the transceiver by holding the antenna.
- **DO NOT** connect the antenna other than listed on page 47.
- Transmitting without an antenna may damage the transceiver.

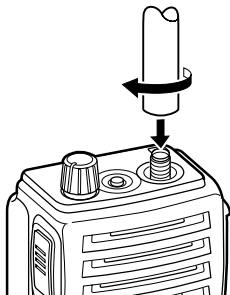

### ◇ Jack cover

Attach the jack cover when the optional speaker-microphone is not used.

When the transceiver is used in a hazardous areas, either the jack cover or HM-138 must be attached to the connector. Failure to do this will make the radio ATEX non-compliant and may result in an accident during use in hazardous areas.

*To attach the jack cover:*

- 1 Insert the jack cover into the [SP MIC] connector.
- 2 Tighten the screw.

*To detach the jack cover:*

- 1 Remove the screw with a phillips screwdriver.
- 2 Detach the jack cover for the speaker-microphone connection.

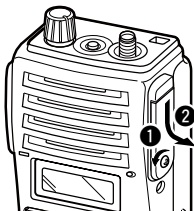
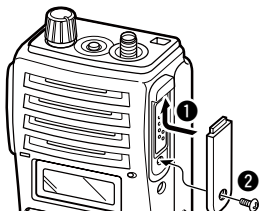

## ◇ Battery pack

*To attach the battery pack:*

Slide the battery pack on the back of the transceiver in the direction of the arrow (1), then lock it with the battery release button.

- Slide the battery pack until the battery release button makes a 'click' sound.

*To remove the battery pack:*

Push the battery release button in the direction of the arrow (2) as shown below. The battery pack is then removed.

**NEVER** remove or attach the battery pack when the transceiver is wet or soiled. This may result in water or dust getting into the transceiver/battery pack and may damage the transceiver.

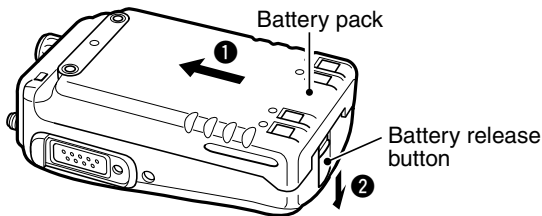

## ◇ Belt clip

Attach the belt clip to the back of the transceiver with the supplied screws.

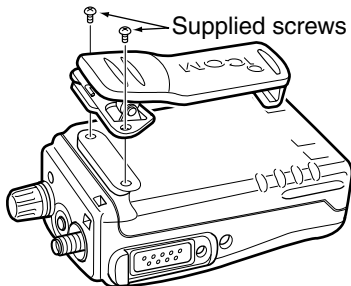

## 2 PANEL DESCRIPTION

### ■ Front, top and side panels

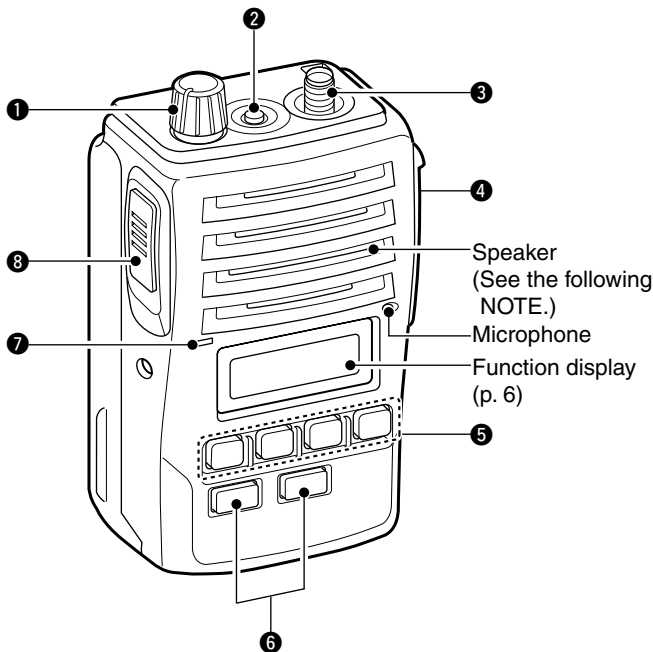

**NOTE:** If the speaker netting (for dust proofing) becomes wet, dry it with a hair drier (cool mode) etc. before operating the transceiver. Otherwise the audio may be difficult to hear for loss of the sound pressure.

**1 VOLUME CONTROL [VOL]**

Turns power ON and adjusts the audio level.

**2 RED BUTTON**

The desired function can be assigned by your dealer.

**3 ANTENNA CONNECTOR**

Connects the supplied antenna.

**4 SPEAKER-MICROPHONE CONNECTOR [SP MIC]**

Connects the optional speaker-microphone. (p. 46)

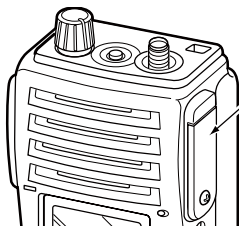

[SP MIC] jack cover

**NOTE:** KEEP the [SP MIC] jack cover attached to the transceiver when the speaker-microphone is not used. (See page 1 for details)

**5 DEALER-PROGRAMMABLE KEYS [P0] to [P3]**

The desired functions can be assigned independently by your dealer.

**6 CH UP AND DOWN KEYS [▲]/[▼]**

- During standby condition, push to select an operating channel.
- After pushing [TX Code CH Select], push to select a TX code channel.
- After pushing [DTMF Autodial], push to select a DTMF channel.
- After pushing and holding [Scan A Start/Stop]/[Scan B Start/Stop], push to select a scan group.
- After pushing [Digital], push to select a BIIS code, status number or SDM.

\*Desired functions can be assigned independently by your dealer.

➤ Continue to the next page.

---

## 2 PANEL DESCRIPTION

### ■ Front, top and side panels (Continued)

#### ⑦ TRANSMIT/BUSY INDICATOR

Lights red while transmitting; lights green while receiving a signal, or when the squelch is open.

#### ⑧ PTT SWITCH [PTT]

Push and hold to transmit; release to receive.

## ■ Function display

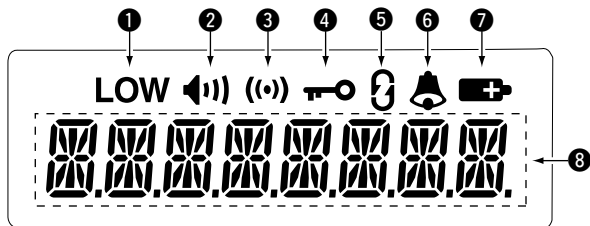

### ① OUTPUT POWER INDICATOR

Appears when Low 2 or Low 1 is selected.

### ② AUDIBLE INDICATOR

- Appears when the channel is in the 'audible' (unmute) condition.
- Appears when the specified 5-tone/BIIS code is received.

### ③ COMPANDER INDICATOR

Appears when the compander function is activated.

### ④ KEY LOCK INDICATOR

Appears during the key lock function ON.

### ⑤ SCRAMBLER INDICATOR

Appears when the voice scrambler function is activated.

### ⑥ BELL INDICATOR

Appears/Blinks when the specific 5-tone/BIIS code is received, according to the programming.

### ⑦ BATTERY INDICATOR

Appears or blinks when the battery power decreases to a specified level.

### ⑧ ALPHANUMERIC DISPLAY

Displays the operating channel number, channel names, Set mode contents, DTMF numbers, etc.

### ■ Programmable function keys

The following functions can be assigned to [P0], [P1], [P2], [P3], [Red], [▼] and [▲] programmable function keys.

Consult your Icom dealer or system operator for details concerning your transceivers programming.

#### ***CH UP AND DOWN KEYS***

- Select an operating channel.
- Select a transmit code channel after pushing the [TX Code CH Select] keys.
- Select a DTMF channel after pushing the [DTMF Autodial] key.
- Select a scan group after pushing and holding the [Scan A Start/Stop]/[Scan B Start/Stop] keys.
- Select a BIIS code, status number or SDM after pushing the [Digital] key.

#### ***BANK SELECT KEY***

Push this key, then push [CH Up] or [CH Down] to select the desired bank.

#### ***SCAN START/STOP KEYS***

- Push this key to start scanning; and push again to stop.
- Push and hold this key to indicate the scan group, then select the desired scan group using [CH Up]/[CH Down].

#### ***SCAN TAG KEY***

Adds or deletes the selected channel to the scan group.



**PRIORITY CHANNEL KEYS**

- Push to select Priority A or Priority B channel.
- Push and hold [Prio A (Rewrite)] to rewrite the Prio A channel.

**MR-CH 1/2/3/4 KEYS**

Select an operating channel directly.

**MONITOR KEY**

Activates one of (or two of) the following functions on each channel independently:

- Push and hold to un-mute the channel (audio is emitted; 'Audible' condition).
- Push to mute the channel (sets to 'Inaudible' only).
- Push to un-mute the channel (sets to 'Audible' only).
- Push after the communication is finished to send a 'reset code'.

 **NOTE:** The un-mute condition ('Audible' condition) may automatically return to the mute condition ('Inaudible' condition) after a specified period.

**LOCK KEY**

Push and hold to electronically lock all programmable keys except the following:

[Call] (incl. Call A and Call B), [Moni(Audi)] and [Emergency] keys.

**OUTPUT POWER SELECTION KEY**

Select the transmit output power temporarily or permanently, depending on the pre-setting.

- Ask your dealer for the output power level for each selection.

---

## 2 PANEL DESCRIPTION

### ***C.TONE CHANNEL ENTER KEY***

Select the continuous tone channel using [CH Up]/[CH Down] keys to change the tone frequency/code setting after pushing this key for permanent operation.

### ***TALK AROUND KEY***

Turn the talk around function ON and OFF.

- The talk around function equalizes the transmit frequency to the receive frequency for transceiver-to-transceiver communication.

### ***WIDE/NARROW KEY***

Push to toggle the IF bandwidth between wide and narrow.

- The wide passband width can be selected from 25.0 or 20.0 kHz using the CS-F50 CLONING SOFTWARE. Ask your dealer for details.

### ***DTMF AUTODIAL KEY***

- Push to enter the DTMF channel selection mode. Then select the desired DTMF channel using [CH Up]/[CH Down] keys.
- After selecting the desired DTMF channel, push this key to transmit the DTMF code.

### ***DTMF RE-DIAL KEY***

Push to transmit the last-transmitted DTMF code.

### ***CALL KEYS***

Push to transmit a 5-tone/BIIS ID code.

- Call transmission is necessary before you call another station depending on your signalling system.
- The [Call A] and/or [Call B] keys may be available when your system employs selective 'Individual/Group' calls. Ask your dealer which call is assigned to each key.

### **EMERGENCY KEYS**

- Push and hold to transmit an emergency call.
- When [Emergency Single (Silent)] or [Emergency Repeat (Silent)] is pushed, an emergency call is transmitted without a beep emission and LCD indication change.
  - If you want to cancel the emergency call, push (or push and hold) the key again before transmitting the call.
  - The emergency call is transmitted one time only or repeatedly until receiving a control code depending on the pre-setting.

### **TX CODE ENTER KEY**

Push to enter the direct ID code edit mode, for both 5-tone and MSK. Then set the desired digit using [CH Up]/[CH Down]/[TX Code CH Up]/[TX Code CH Down]. (p. 16)

### **TX CODE CHANNEL SELECT KEY**

- Push to enter the direct ID code channel selection mode. Then set the desired channel using [CH Up]/[CH Down]/[TX Code CH Up]/[TX Code CH Down]. (p. 15)
- While in ID code channel selection mode, push for 1 sec. to enter the ID code edit mode. Then set the desired digit using [CH Up]/[CH Down]/[TX Code CH Up]/[TX Code CH Down]. (p. 16)

### **TX CODE CHANNEL UP/DOWN KEYS**

Push to select a TX code channel directly.

### **ID MEMORY READ KEY**

- Recalls detected ID codes.
  - Push this key, then push [CH Up]/[CH Down] for selection.
  - Up to 5 ID's are memorized.
- Push and hold to erase the selected memorized ID's.

---

## 2 PANEL DESCRIPTION

### **VOICE SCRAMBLER FUNCTION**

Push to toggle the voice scrambler function ON and OFF.

### **COMPANDER KEY**

Push to toggle the compander function ON and OFF.

The compander function reduces noise components from the transmitting audio to provide clear communication.

### **USER SET MODE KEY**

- Push and hold to enter the User Set mode.
  - During the User Set mode, push this key to select an item that is enabled by your dealer, and push [CH Up]/[CH Down] to change the value or condition.
- Push and hold this key again to exit the User Set mode.

### **DIGITAL KEY** (BIIS operation only)

- Push to select the call ID list, transmit message and standby condition. Toggles between queue channel and received message record indication after queue channel is selected.
- Push and hold to select queue channel indication.

### **STATUS UP/DOWN KEYS** (BIIS operation only)

- While in the standby condition, push to display the transmit status indication and select a status number.
- When a received SDM is displayed, push to cancel the automatic scroll and scroll the message manually.
- When an SDM that contains more than 8 characters is displayed, push to scroll the message manually.

## ■ Turning power ON

- ① Rotate [VOL] to turn power ON.
- ② If the transceiver is programmed for a start up passcode, input digit codes as directed by your dealer.
  - The keys in the table below can be used for password input:
  - The transceiver detects numbers in the same block as identical. Therefore “01234” and “56789” are the same.

KEY	P <sub>0</sub>	P <sub>1</sub>	P <sub>2</sub>	P <sub>3</sub>	▼ / ▲
NUMBER	0	1	2	3	4
	5	6	7	8	9

- ③ When the “PASSWORD” indication does not clear after inputting 4 digits, the input code number may be incorrect. Turn the power off and start over in this case.

## ■ Channel selection

Several types of channel selections are available. Methods may differ according to your system set up.

### **NON-BANK TYPE:**

Push [▼]/[▲] to select the desired operating channel, in sequence; or, push one of the [MR-CH 1] to [MR-CH 4] keys to select a channel directly.

### **BANK-TYPE:**

Push [Bank], then push [▼] or [▲] to select the desired bank.

### **AUTOMATIC SCAN TYPE:**

Channel setting is not necessary for this type. When turning the power ON, the transceiver automatically starts scanning. Scanning stops when receiving a call.

**NOTE:** If the Move to Priority A channel at Power ON function is turned ON, the transceiver does not start scanning at power ON. Consult your Icom dealer or system operator for details.

## ■ Call procedure

When your system employs tone signalling (excluding CTCSS and DTCSS), the call procedure may be necessary prior to voice transmission. The tone signalling employed may be a selective calling system which allows you to call specific station(s) only and prevent unwanted stations from contacting you.

- ① Select the desired TX code channel or 5-tone code according to your System Operator's instructions.
  - This may not be necessary depending on programming.
  - Refer to pages 15 and 16 for selection.
- ② Push the call switch (assigned to one of the dealer programmable switches: **[P0]**, **[P1]**, **[P2]**, **[P3]**, **[Red]**, **[▼]** and **[▲]**).
- ③ After transmitting a 5-tone code, the remainder of your communication can be carried out in the normal fashion.

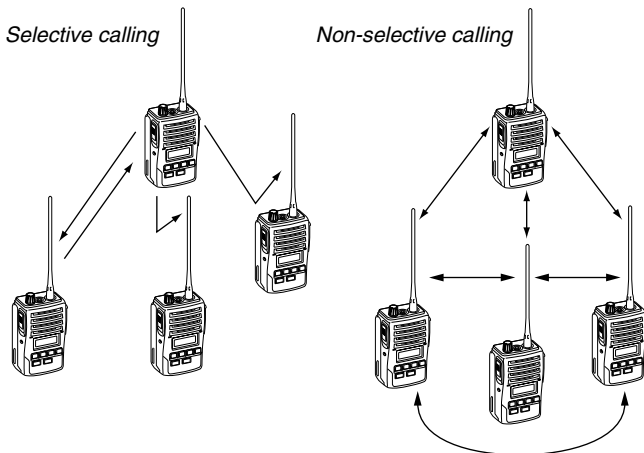

## ■ Receiving and transmitting

 **NOTE:** Transmitting without an antenna may damage the transceiver. See page 1 for antenna attachment.

3

### *Receiving:*

- ① Rotate [VOL] to turn power ON.
- ② Push [▼] or [▲] to select a channel.
- ③ When receiving a call, adjust the audio output level to a comfortable listening level.

### *Transmitting:*

Wait for the channel to become clear to avoid interference.

- ① While pushing and holding [PTT], speak into the microphone at a normal voice level.
  - When a tone signalling system is used, the call procedure described at left may be necessary.
- ② Release [PTT] to return to receive.

 **IMPORTANT:** To maximize the readability of your signal;

1. Pause briefly after pushing [PTT].
2. Hold the microphone 5 to 10 cm from your mouth, then speak into the microphone at a normal voice level.

#### ◇ Transmitting notes

##### • Transmit inhibit function

The transceiver has several inhibit functions which restrict transmission under the following conditions:

- The channel is in mute condition ('Inaudible' condition; "🔇") does not appear).
- Channel is busy.
- Un-matched (or matched) CTCSS is received.
- The selected channel is a 'receive only' channel.

##### • Time-out timer

After continuous transmission for the pre-programmed time period, the time-out timer is activated, causing the transceiver to stop transmitting.

##### • Penalty timer

Once the time-out timer is activated, transmission is further inhibited for a period determined by the penalty timer.

#### ◇ TX code channel selection

If the transceiver has [TX Code CH Select] assigned to it, indication can be toggled between the operating channel number (or name) and TX code channel number (or name). When the TX code channel number (or name) is displayed, the [▼]/[▲] key selects the TX code channel.

##### **TO SELECT A TX CHANNEL:**

- ① Push [TX Code CH Select]— a TX code channel appears.
- ② Push [▼]/[▲] to select the desired TX code channel.
- ③ Push [Call] (or [PTT] during MSK operation) to transmit the selected TX code.
- ④ Push [TX Code CH Select] again to return to the operating channel number indication.

##### **FOR TX CODE CHANNEL TYPE:**

If the transceiver has a [TX Code CH Up] or [TX Code CH Down] key assignment, the programmed TX code channel can be selected directly.



## ◇ TX code number edit

If the transceiver has [TX Code CH Select] or [TX Code Enter] assigned to it, TX code contents can be edited within the allowable digits.

### ***TO EDIT A TX CODE VIA [TX CODE CH SELECT] KEY:***

- ① Push [TX Code CH Select] to enter the TX code channel selection mode.
  - Select the desired channel using [▼]/[▲] if necessary.
- ② Push [TX Code CH Select] for 1 sec. to enter the TX code edit mode.
- ③ Push [TX Code CH Select] to select the desired digit to be edited.
- ④ Set the desired digit using [▼]/[▲]/[TX Code CH Up]/[TX Code CH Down].
- ⑤ Push [TX Code CH Select] to set the digit. The editable digit will move to the right automatically.
- ⑥ Repeat ④ and ⑤ to input all allowable digits.
- ⑦ Push [Call] or [PTT] to transmit the selected TX code.

### ***TO EDIT A TX CODE VIA [TX CODE ENTER] KEY:***

- ① Select the desired TX code channel via [TX Code CH Up]/[TX Code CH Down].
- ② Push [TX Code Enter] to enter the TX code edit mode.
- ③ Push [TX Code Enter] to select the desired digit to be edited.
- ④ Set the desired digit using [▼]/[▲]/[TX Code CH Up]/[TX Code CH Down].
- ⑤ Push [TX Code Enter] to set the digit. The editable digit will move to the right automatically.
- ⑥ Repeat ④ and ⑤ to input all allowable digits.
- ⑦ Push [Call] or [PTT] to transmit the selected TX code.

---

### 3 CONVENTIONAL OPERATION

#### ◇ DTMF transmission



If the transceiver has [DTMF Autodial] assigned to it, the automatic DTMF transmission function is available. Up to 8 DTMF channels are available.

##### **TO SELECT A TX CODE:**

- ① Push [DTMF Autodial]— a DTMF channel appears.
- ② Push [▼]/[▲] to select the desired DTMF channel.
- ③ Push [DTMF Autodial] to transmit the DTMF code in the selected DTMF channel.

## ■ Scrambler function

The voice scrambler function provides private communication between stations. The frequency inversion type is equipped to all versions, and some versions have the Rolling or Non-rolling type installed.

- ① Push [Scrambler] to turn the scrambler function ON.
  - “” appears.
- ② Push [Scrambler] again to turn the scrambler function OFF.
  - “” disappears.

## ■ User Set mode

If the transceiver has [User Set Mode] assigned to it, you can “customize” the transceiver operation to suit your preferences and operating style.

3

### ***Entering the User Set mode:***

- ① Push and hold [User Set Mode] for 1 sec. to enter the User Set mode.
- ② Push [User Set Mode] momentarily to select the appropriate item.  
Then push [CH Up] or [CH Down] to set the desired level/condition.

### **Available set mode functions:**

- Backlight : ON, Auto or OFF
  - Beep : ON or OFF
  - SQL Level : 0 to 255
  - AF Min level : ON or OFF
  - Mic Gain : 1 to 5
  - Battery Voltage : ON or OFF
- ③ Push and hold [User Set Mode] for 1 sec. again to exit the User Set mode.

# 4 BIIS OPERATION

---



## ■ Default setting

The following functions are assigned to each programmable key as the default. Ask your dealer for details.

- [P0]; Call : Push to transmit a 5-tone/BIIS call when the selected channel is a 5-tone or MSK channel, respectively.
- [P1]; Digital : Push to select the call list ID/transmit message, or to display the receive message record for selection.
- [P3]; Moni(Audi) : Push this key after the communication to send a "clear down" signal during MSK channel operation.
- [▼]/[▲]; CH Down/Up : While in the standby condition, selects the operating channel.  
After pushing [Digital] or [TX Code CH Select], push to select the call list or TX code channel, respectively.
- [P2]/[Red]; Null : No function is assigned.

## ■ Receiving a call

### ◇ Individual call

- ① When an individual call is received;
  - Beeps sound.
  - “” appears and the mute is released.
  - The programmed text message (e.g. “CALLING”) and the calling station ID (or text) is displayed alternately, depending on the setting.
  - “” appears or blinks depending on the setting.

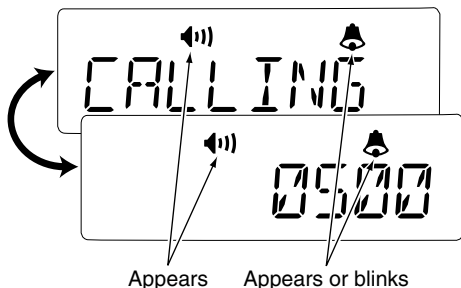

- ② Push and hold [PTT], then speak into the microphone at a normal voice level.
  - Transmit/Busy indicator lights red.
- ③ Release [PTT] to return to receive.
  - Transmit/Busy indicator lights green while receiving a signal.
- ④ To finish the conversation, push [P3] (Moni(Audi)) to send the “Clear down” signal.
  - Either station can send a clear down signal.
  - “CLR DOWN” is displayed for 2 sec. (approx.).
  - “” disappears and the transceiver returns to the standby condition.

## 4 BIIS OPERATION

### ◇ Group call

- ① When a group call is received;
  - Beeps sound.
  - “

Appears      Appears or blinks

- ② Push and hold [PTT], then speak into the microphone at a normal voice level.
  - ⚡ **NOTE:** Only one station is permitted to speak.
  - Transmit/Busy indicator lights red.
- ③ Release [PTT] to return to receive.
  - Transmit/Busy indicator lights green while receiving a signal.
- ④ To finish the conversation, push [P3] (Moni(Audi)) to send the “Clear down” signal.
  - Either station can send a clear down signal.
  - “CLR DOWN” is displayed for 2 sec. (approx.)
  - “

21

## ◇ Displaying the received call record — Queue indication

The transceiver memorizes the calling station IDs for record. Up to 3 calls can be memorized, and the oldest call record is erased when a 4th call is received. However, once the transceiver is powered OFF, the all records are cleared.

- ① Push [P1] (Digital) for 1 sec.
  - Displays following indication.

### *When a record is available*



--QUEUE1--

### *When no record is available*



NO QUEUE

- ② Push [▼]/[▲] to select the desired call.
- ③ Push [P1] (Digital) for 1 sec. again to return to the standby condition.
  - When no operation is performed for 30 sec., the transceiver returns to the standby condition automatically.

### ■ Transmitting a call

Total of a 3 ways for code selection are available—selecting the call code from memory, entering the call code from the keypad and calling back from the queue channel record.

#### ◇ Using call memory

- ① While in the standby condition, push [P1] (Digital) to enter the call code memory channel selection mode.

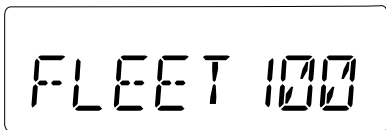

Call code text is displayed.

- ② Push [▼]/[▲] to select the desired call code.
- ③ Push [P0] (Call) or [PTT]\* to call.  
\*PTT call can be made only when PTT call capability is permitted.

**NOTE:** When no answer back is received, the transceiver repeats the call 3 times (default) automatically, and “WAIT” is displayed during each call. However, an error beep sounds and “FAILED” is displayed when no answer back is received after the calls.

- ④ Push [PTT] to transmit; release to receive.
- ⑤ Push [P3] (Moni(Audi)) to send the “Clear down” signal.



### ◇ Calling back from the queue channel

- ① While in the standby condition, push [P1] (Digital) for 1 sec. to enter queue memory channel selection mode.
- ② Push [▼]/[▲] to select the desired record.



--QUEUE 1--

- ③ Push [P0] (Call) or [PTT]\* to call.

\*PTT call can be made only when PTT call capability is permitted.

**NOTE:** When no answer back is received, the transceiver repeats the call 3 times (default) automatically, and "WAIT" is displayed during each call. However, an error beep sounds and "FAILED" is displayed when no answer back is received after the calls.

- ④ Push [PTT] to transmit; release to receive.
- ⑤ Push [P3] (Moni(Audi)) to send the "Clear down" signal.

---

## 4 BIIS OPERATION

### ◇ Direct code entry

- ① While in the standby condition, push [TX Code Enter] to enter the TX code edit mode.
  - Editable code digit blinks.

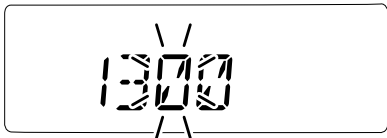

- ② Push [TX Code Enter] to select the desired digit to be edited.
  - Editable digit differs according to the setting.
- ③ Set the desired digit using [▼]/[▲]/[TX Code CH Up]/[TX Code CH Down].
- ④ Push [TX Code Enter] to set the digit. The editable digit will move to the right automatically.
- ⑤ Repeat ③ and ④ to input all allowable digits.
- ⑥ Push [P0] (Call) or [PTT]\* to call.

\*PTT call can be made only when PTT call capability is permitted.

**NOTE:** When no answer back is received, the transceiver repeats the call 3 times (default) automatically, and "WAIT" is displayed during each call. However, an error beep sounds and "FAIL" is displayed when no answer back is received after the calls.

- ⑦ Push [PTT] to transmit; release to receive.
- ⑧ Push [P3] (Moni(Audi)) to send the "Clear down" signal.

---

### **For your information**

When the "UpDate" setting for the call code is enabled, the set code is overwritten into the call code memory.

---

## ■ Receiving a message

### ◇ Receiving a status message

- ① When a status message is received;
  - Beeps sound.
  - The calling station ID (or text) and the status message is displayed alternately, depending on the setting.

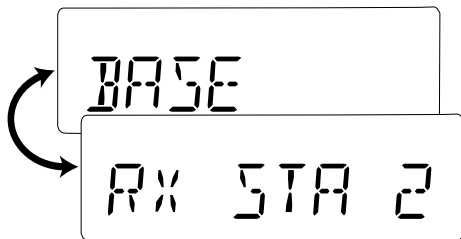

- ② Push [P3] (Moni(Audi)) to return to the standby condition.

**NOTE:** Only the calling station ID (or text) is displayed (no message is displayed alternately) when the scroll timer is set to "OFF". In this case, push [Status Up]/[Status Down] to display the status message manually.

---

## 4 BIIS OPERATION

### ◇ Receiving an SDM

- ① When an SDM is received;
  - Beeps sound.
  - The calling station ID (or text) and the SDM is displayed alternately, depending on the setting.

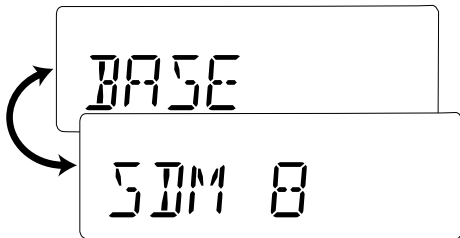

- ② When the received SDM includes more than 8 characters, the message scrolls automatically, when the automatic scroll function is activated.
  - Push [Status Up]/[Status Down] to scroll the message manually.
- ③ Push [P3] (Moni(Audi)) to return to the standby condition.

## ◇ Received message selection

The transceiver memorizes the received messages for record. Up to 6 messages for status and SDM, or 95 character SDM's can be memorized. The oldest message is erased when the 7th message is received. However, once the transceiver is powered OFF, all messages are cleared.

- ① Push [P1] (Digital) for 1 sec.
  - Displays queue memory.
- ② Push [P1] (Digital) momentarily.
  - Displays message memory.

### *When a message is available*

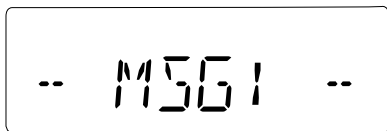

### *When no message is available*

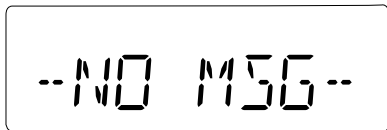

- ③ Push [▼]/[▲] to select the desired message.
  - When selecting the SDM that includes more than 8 characters, the message scrolls automatically, when the automatic scroll function is activated.
  - Push [Status Up]/[Status Down] to scroll the message manually.
- ④ Push [P1] (Digital) for 1 sec. again to return to the standby condition.
  - When no operation is performed for 30 sec., the transceiver returns to the standby condition automatically.

## ■ Transmitting a status

### ◇ General

The status message can be selected with the programmed text, and the message text is also displayed on the function display of the called station.

Up to 24 status types (1 to 24) are available, and the status messages 22 and 24 have designated meanings.

Status 22: Emergency\*

Status 24: GPS request

\*The status 22 can also be used as a normal status message by disabling the designated meaning. However, the status 24 is fixed.

The status call can be sent with both individual and group calls.

### ◇ Transmitting a status

- ① While in the standby condition, push [P1] (Digital), then push [▼]/[▲] to select the desired station/group code.
- ② Push [P1] (Digital) again, then push [▼]/[▲] to select the desired status message.

Or, you can select the desired status message using [Status Up]/[Status Down] key directly.

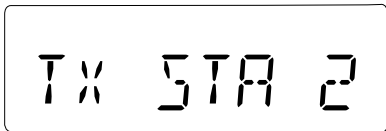

Status message is displayed.

- ③ Push [P0] (Call) or [PTT]\* to transmit the status message to the selected station/group.

\*PTT call can be made only when PTT call capability is permitted.

- 2 beeps will sound and the transceiver returns to the standby condition automatically when the transmission is successful.

## ■ Transmitting an SDM

### ◇ General

The short data message, SDM, can be sent to an individual station or group stations. Also, 8 SDM memory channels are available and the messages can be edited via PC programming.

4

### ◇ Transmitting an SDM

- ① While in the standby condition, push [P1] (Digital), then push [▼]/[▲] to select the desired station/group code.
- ② Push [P1] (Digital) again, then push [▼]/[▲] to select the desired SDM.

Or, you can select the desired SDM using [Status Up]/[Status Down] key directly.



SDM 8

SDM is displayed.

- ③ Push [P0] (Call) or [PTT]\* to transmit the SDM to the selected station/group.  
\*PTT call can be made only when PTT call capability is permitted.
  - 2 beeps will sound and the transceiver returns to the standby condition automatically when the transmission is successful.

### ■ Position data transmission

When the optional OPC-966 INTERFACE CABLE and a GPS receiver is connected to the transceiver, the position (longitude and latitude) data can be transmitted automatically.

Ask your dealer or system operator for connection details.

The position data is transmitted when;

- Status 24 message is received  
\*When the status 24 message, GPS request, is received.

- Fully automatic

When automatic position transmission is enabled, send the position data according to 'Time Marker' and 'Interval Timer' settings.

- PTT is released

When 'Send with Logoff' is enabled.

- Set the "Log-In/Off" item as "L-OFF".

- After sending a status message

When 'Send with Status' is enabled.

- After sending an SDM

When 'Send with SDM' is enabled.

- After sending status 22 (Emergency)

When 'Send with Emergency' is enabled.



## ■ Printer connection

When the optional OPC-966 INTERFACE CABLE is connected to the transceiver, a printer can be connected to print out the received SDM content and the ID of the station who sent the message.

Ask your dealer or system operator for connection details.

4

## ■ PC connection

When the optional OPC-966 INTERFACE CABLE is connected to the transceiver, a PC can be connected to provide remote control, data reception, etc.

Ask your dealer or system operator for connection details.

## ■ Digital ANI

The own ID can be transmitted each time the PTT is pushed (log-in) or released (log-off) during individual or group call communications.

By receiving the ANI, the communication log can be recorded when using a PC dispatch application.

In addition, when using the ANI with log-in, the PTT side tone function can be used to inform you that the ID is sent and voice communication can be performed.

### ■ Auto emergency transmission

When [Emergency Single (Silent)] or [Emergency Repeat (Silent)] is pushed, an emergency signal is automatically transmitted for the specified time period.

The status 22 (Emergency) is sent to the selected ID station, and the position data is transmitted after the emergency signal when a GPS receiver is connected to the transceiver.

The emergency transmission is performed on the emergency channel, however, when no emergency channel is specified, the signal is transmitted on the previously selected channel.

There is no change in the function display or beep emission during automatic emergency transmission.

### ■ Stun function

When the specified ID, set as a killer ID, is received, the stun function is activated.

When the killer ID is received, the transceiver switches to the passcode required condition. Entering of the passcode via the keypad is necessary to operate the transceiver again in this case.

## ■ BIIS indication

The following indications are available for the BIIS operation on an MSK channel.

*CONNECT* : Individual/group call is successful.

*OK* : Message (status or SDM) transmission is successful.

*FAILED* : No answer back is received.

*WAIT* : Appears during retry of the call (2nd call).

*CLR DOWN*: End the communication.

*BUSY* : Operating channel is in the busy condition.

4

## ■ Priority A channel selection

When one of the following operations is performed, the transceiver selects the Priority A channel automatically.

Priority A is selected when;

- Clear down signal is received/transmitted
  - Set the “Move to PrioA CH” item as “Clear Down”.
- Turning the power ON
  - The Priority A channel is selected each time the transceiver power is turned ON.
- Status call
  - The Priority A channel is selected when transmitting a status call.
  - Enable the “Send Status on PrioA CH” item in the MSK configuration.

# 5 BATTERY CHARGING

## ■ Caution

Misuse of Lithium-ion batteries may result in the following hazards: smoke, fire, or the battery may rupture. Misuse can also cause damage to the battery or degradation of battery performance.

 **WARNING! NEVER** charge the battery (with/without the transceiver) in an explosive atmosphere. The optional battery chargers are not approved as Intrinsically Safe.

 **DANGER!** Use and charge only specified Icom battery packs with Icom radios or Icom charger. Only Icom battery packs are tested and approved for use and charge with Icom radios or Icom charger. Using third-party or counterfeit battery packs or charger may cause smoke, fire, or cause the battery to burst.

## ◇ Battery caution

⚠ **DANGER! DO NOT** hammer or otherwise impact the battery. Do not use the battery if it has been severely impacted or dropped, or if the battery has been subjected to heavy pressure. Battery damage may not be visible on the outside of the case. Even if the surface of the battery does not show cracks or any other damage, the cells inside the battery may rupture or catch fire.

⚠ **DANGER! NEVER** use the transceiver or the battery if either one is damaged, shows cracks, bruises or is deformed.

⚠ **DANGER! NEVER** use or leave battery packs in areas with temperatures above +60°C. High temperature buildup in the battery, such as could occur near fires or stoves, inside a sun heated car, or in direct sunlight may cause the battery to rupture or catch fire. Excessive temperatures may also degrade battery performance or shorten battery life.

⚠ **DANGER! DO NOT** expose the battery to rain, snow, seawater, or any other liquids. Do not charge or use a wet battery. If the battery gets wet, be sure to wipe it dry before using. The battery is not waterproof.

⚠ **DANGER! NEVER** incinerate used battery packs since internal battery gas may cause them to rupture, or may cause an explosion.

⚠ **DANGER! NEVER** solder the battery terminals or NEVER modify the battery pack. This may cause heat generation, and the battery may rupture, emit smoke or catch fire.

⚠ **DANGER!** Use the battery only with the transceiver for which it is specified. Never use a battery with any other equipment, or for any purpose that is not specified in this instruction manual.

➡ Continue to the next page.

---

## 5 BATTERY CHARGING

### ■ Caution

#### ◇ Battery caution (Continued)

⚠ **DANGER!** If fluid from inside the battery gets in your eyes, blindness can result. Rinse your eyes with clean water, without rubbing them, and see a doctor immediately.

⚠ **WARNING!** Immediately stop using the battery if it emits an abnormal odor, heats up, or is discolored or deformed. If any of these conditions occur, contact your Icom dealer or distributor.

⚠ **WARNING!** Immediately wash, using clean water, any part of the body that comes into contact with fluid from inside the battery.

⚠ **WARNING! NEVER** put the battery in a microwave oven, high-pressure container, or in an induction heating cooker. This could cause a fire, overheating, or cause the battery to rupture.

**CAUTION:** Always use the battery within the specified temperature range for the transceiver ( $-20^{\circ}\text{C}$  to  $+55^{\circ}\text{C}$ ) and the battery itself ( $-10^{\circ}\text{C}$  to  $+60^{\circ}\text{C}$ ). Using the battery out of its specified temperature range will reduce the battery's performance and battery life. Please note that the specified temperature range of the battery may exceed that of the transceiver. In such cases, the transceiver may not work properly because it is out of its operating temperature range.

**CAUTION:** Shorter battery life could occur if the battery is left fully charged, completely discharged, or in an excessive temperature environment (above  $+45^{\circ}\text{C}$ ) for an extended period of time. If the battery must be left unused for a long time, it must be detached from the radio after discharging.

You may use the battery until the remaining capacity is about half, then keep it safely in a cool dry place with the temperature range as below:

- $20^{\circ}\text{C}$  to  $+45^{\circ}\text{C}$  (within a month)
- $20^{\circ}\text{C}$  to  $+40^{\circ}\text{C}$  (within six months)
- $20^{\circ}\text{C}$  to  $+35^{\circ}\text{C}$  (within a year)

**BE SURE** to replace the battery with a new one after five years, even if still holds a charge. The inside battery material will deteriorate after a period of time, even with little use.

### ◇ Charging caution

△ **DANGER! NEVER** charge the battery pack in areas with extremely high temperatures, such as near fires or stoves, inside a sun heated car, or in direct sunlight. In such environments, the safety/protection circuit in the battery will activate, causing the battery to stop charging.

△ **WARNING! DO NOT** charge or leave the battery in the battery charger beyond the specified time for charging. If the battery is not completely charged by the specified time, stop charging and remove the battery from the battery charger. Continuing to charge the battery beyond the specified time limit may cause a fire, overheating, or the battery may rupture.

△ **WARNING! NEVER** insert the transceiver (battery attached to the transceiver) into the charger if it is wet or soiled. This could corrode the battery charger terminals or damage the charger. The charger is not waterproof.

**CAUTION: DO NOT** charge the battery outside of the specified temperature range: BC-152N (0°C to +45°C). Icom recommends charging the battery at +20°C. The battery may heat up or rupture if charged out of the specified temperature range. Additionally, battery performance or battery life may be reduced.

## ■ Optional battery chargers

### ◇ Regular charging with the BC-152N

- ① Attach the BC-152N to a flat surface, such as a desk, if desired.
- ② Connect the AC adapter as shown below.
- ③ Insert the battery pack with/without the transceiver into the charger.
  - The charge indicator lights green.
- ④ Charge the battery pack approximately 10 hours, depending on the remaining power condition.
  - The charge indicator goes off when charging is complete.

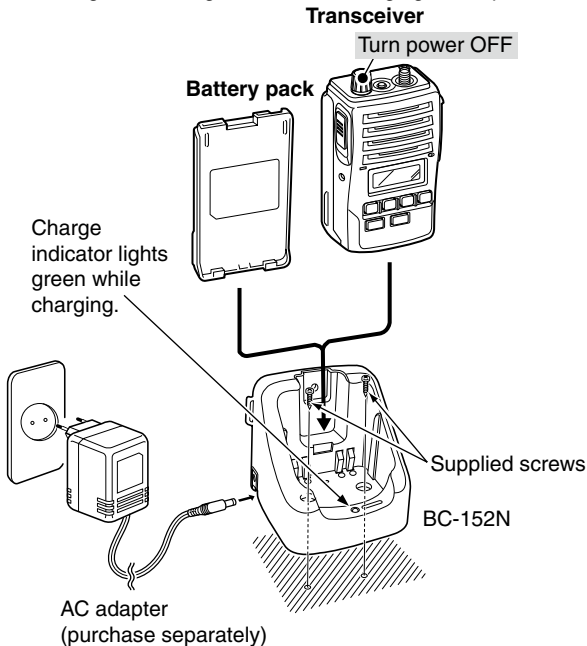



**○ Charging indicator:**

- Lights orange while charging.
- Lights green when charging is completed.
- Blinks orange or green, or does not light when a problem is detected.

**SOLUTIONS:**

- Remove the battery pack, and reinsert it.
- Remove the battery pack, clean the battery terminals, then reinsert it.
- If the battery pack temperature is high, remove and let it cool down, then reinsert it.

If you are unable to solve the problem through the use of these solutions, the battery pack or the charger may be damaged, or the battery life may be over. In that case, contact your nearest Icom Dealer or Service Center.

**NOTE:**

After charging is completed, the BC-152N will automatically recharge the battery pack when the battery voltage decreases. If the battery pack is often left in the charger for long periods, the battery life cycle will be shorter.

**◇ For your convenience**

**Eyelet**  
USE a rubber band to secure the transceiver while charging, if desired.

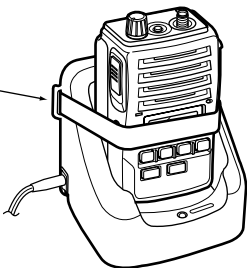

## 5 BATTERY CHARGING

### ■ Optional battery chargers (Continued)

#### ◇ AD-100 installation

The AD-100 CHARGER ADAPTER must be installed into the BC-119N or BC-121N before battery charging.

- ① Attach the plugs from the BC-119N/BC-121N to the AD-100 CHARGER ADAPTER.
- ② Secure the AD-100 into the holder space of the BC-119N/BC-121N with the supplied screws.

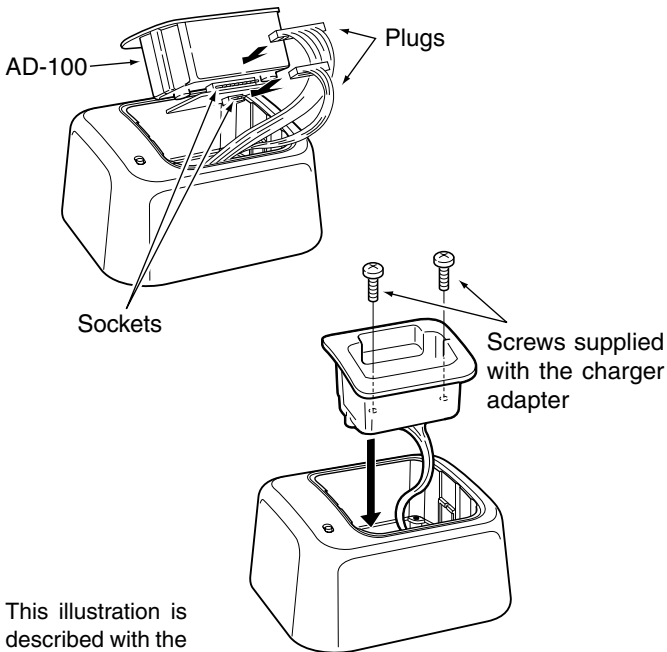

This illustration is described with the BC-119N.

## ◇ Rapid charging with the BC-119N+AD-100

The optional BC-119N provides rapid charging of Li-ion battery pack.

The following are additionally required:

- One AD-100 (purchase separately)
- An AC adapter (may be supplied with BC-119N depending on version) or the DC power cable (OPC-515L/CP-23L).

5

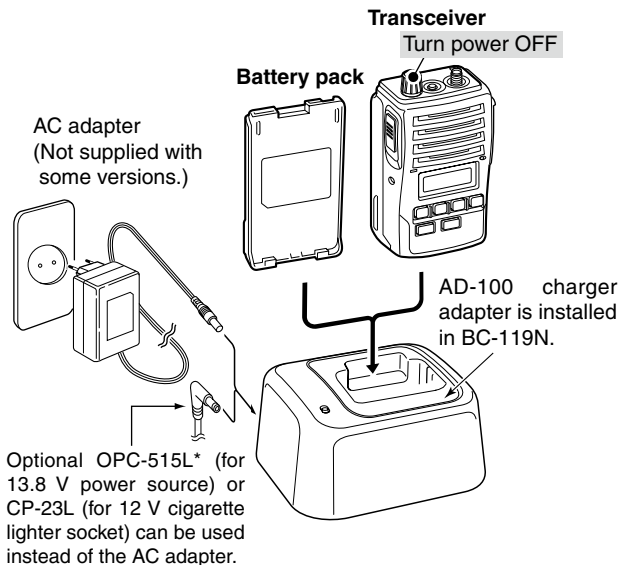

**\*CAUTION: NEVER** connect the OPC-515L to a power source using reverse polarity. This will ruin the battery charger.  
White line: ⊕ Black line: ⊖

## 5 BATTERY CHARGING

### ■ Optional battery chargers (Continued)

#### ◇ Rapid charging with the BC-121N+AD-100

The optional BC-121N allows up to 6 battery packs to be charged simultaneously. The following are additionally required.

- Six AD-100 (purchase separately)
- An AC adapter (BC-157) or the DC power cable (OPC-656)

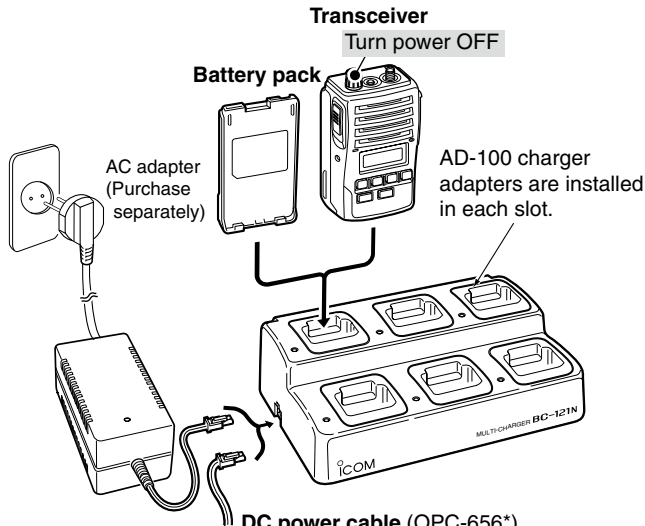

#### DC power cable (OPC-656\*)

(Connect with a DC power supply;  
13.8 V/at least 7 A)

**\*CAUTION: NEVER** connect the OPC-656 to a power source using reverse polarity. This will ruin the battery charger.  
Red line: ⊕ Black line: ⊖

**IMPORTANT: Battery charging caution**

Ensure the guide tabs on the battery pack are correctly aligned with the guide rails inside the charger adapter.  
(This illustration shows the BC-152N.)

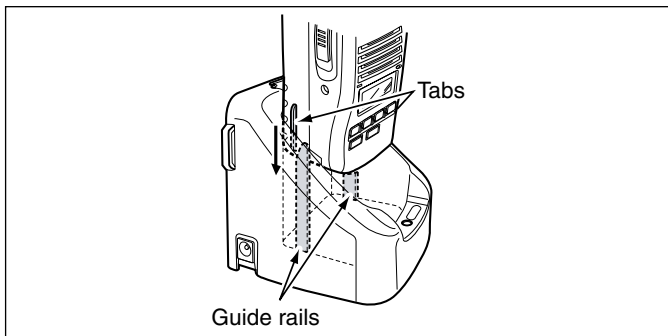

# 6 SPEAKER-MICROPHONE

## ■ Optional HM-138 description

**Alligator type clip**  
To attach the speaker-mic.  
to your shirt or collar, etc.

**PTT switch**  
Transmits while pushed  
Receives while released

**Microphone**

**Speaker**

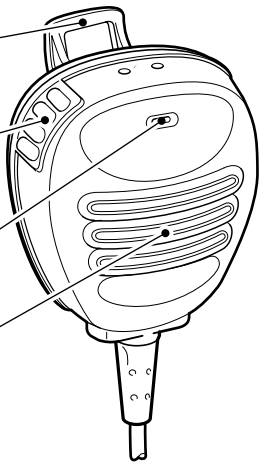

**NEVER** immerse the connector in water. If the connector becomes wet, be sure to dry it **BEFORE** attaching it to the transceiver.

**NOTE:** The microphone is located at the top of the speaker-microphone, as shown in the diagram above. To maximize the readability of your transmitted signal (voice), hold the microphone approx. 5 to 10 cm from your mouth, and speak in a normal voice level.

## ■ Attachment

Attach the connector of the speaker-microphone into the [SP MIC] connector on the transceiver and tighten the screw.

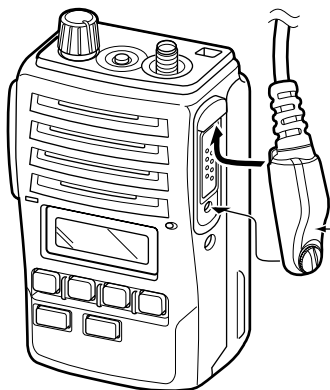

**CAUTION:** Attach the speaker-microphone's connector securely to prevent accidental dropping, or water intrusion in the connector.

**IMPORTANT:** KEEP the [SP MIC] jack cover attached (transceiver) when the speaker-microphone is not in use. Water will not get into the transceiver even if the cover is not attached, however, the terminals (pins) will become rusty, or the transceiver will function abnormally if the connector becomes wet.

**CAUTION:** For ATEX compliance in hazardous areas, the jack cover just also be attached when the HM-138 is not being used.

# 7 OPTIONS

- **BP-227AXD** Li-Ion BATTERY PACK  
7.4 V/1850 mAh/14 Wh Li-ion battery pack. The same as supplied with the transceiver. BP-227AXD must be charged with the optional BC-152N or the BC-119N/121N.
- **BC-152N** DESKTOP CHARGER + **BC-147S** AC ADAPTER  
Used for regular charging of the battery pack. The AC adapter, BC-147S, must be purchased separately.  
Charging time: approx. 9–10 hours
- **BC-119N** DESKTOP CHARGER + **AD-100** CHARGER ADAPTER + **BC-145S** AC ADAPTER  
For rapid charging of battery packs. An AC adapter is not supplied with some versions.  
Charging time: approx. 2 to 2.5 hours
- **BC-121N** MULTI-CHARGER + **AD-100** CHARGER ADAPTER (6 pcs.) + **BC-157S** AC ADAPTER  
For rapid charging of up to 6 battery packs (six AD-100's are required) simultaneously. An AC adapter should be purchased separately.  
Charging time: approx. 2 to 2.5 hours
- **HM-138** SPEAKER-MICROPHONE  
Full-sized speaker-microphone including alligator type clip to attach to your shirt or collar, etc.
- **MB-98** BELT CLIP
- **MB-86** SWIVEL BELT CLIP
- **MB-96F** LEATHER BELT HANGER
- **FA-S62VS/FA-S63VS/FA-S57US** STUBBY ANTENNA  
FA-S62VS: 150–162 MHz      FA-S63VS: 160–174 MHz  
FA-S57US: 450–490 MHz

Some options may not be available in some countries. Please ask your dealer for details.



Approved Icom optional equipment is designed for optimal performance when used with an Icom transceiver.

Icom is not responsible for the destruction or damage to an Icom transceiver in the event it is used with equipment that is not manufactured or approved by Icom.

Some options may not be available in some countries. Please ask your dealer for details.

# 8

## ATEX CAUTIONS

---

### ◇ **Special conditions for safe use**

The equipment is an intrinsically safe equipment. It can be used in a potentially explosive atmosphere.

The equipment must be powered only by the battery Icom type BP-227AXD.

When the transceiver is used in a hazardous areas, either the jack cover or HM-138 must be attached to the connector. Failure to do this will make the radio ATEX non-compliant and may result in an accident during use in hazardous areas.

The battery shall be charged only in non hazardous areas.

The battery shall be changed only in non hazardous areas.

Ambient operating temperature:  $-20^{\circ}\text{C}$  to  $+55^{\circ}\text{C}$

## ◇ Meaning of ATEX marking codes



↑ Ambient temperature



↑ CE conformity marking    ↑ Identification number of notified body (where appropriate) (LCIE: 0081)

Equipment category:  
1 (for Zone 0 or 20), 2 (for Zone 1 or 21),  
3 (for Zone 2 or 22)

II 2G    II 2D

Type of Explosive atmosphere:  
G (for gas, vapors and mist), D (for dusts)

Equipment group:  
I (for mines), II (for other than mines)

Intrinsic safety according EN60079-0 and EN60079-11

Gas Group (see Fig. 1)    Gas/Equipment Protection Level (EPL)

Ex ib II A T3 Gb

Equipment conforms to types of protection standardized by CENELEC (European standards)

↑ Marking temperatures (see Fig. 1)

Dust Group    Dust/Equipment Protection Level (EPL)

Ex tb III C T160°C Db IP67

↑ Protection by enclosures according EN60079-0 and EN60079-31

↑ Max surface temperature

↑ IP Code

		Max. Temperature						
Gas Group		T1: 450°C	T2: 300°C	T3: 200°C	T4: 135°C	T5: 100°C	T6: 85°C	
<b>I</b>	Methane	—	—	—	—	—	—	
	Acetone	Ethyl alcohol	Benzine	Acetalde hyde	—	—	—	
<b>IIA</b>	Ethane	I-amyl acetate	Diesel fuel	Ethyl ether	—	—	—	
	Ethyl acetate	n-butane	Aircraft fuel	—	—	—	—	
	Ammonia	n-butyl alcohol	Heating oil	—	—	—	—	
	Benzene (pure)	—	n-hexane	—	—	—	—	
	Acetic acid	—	—	—	—	—	—	
	Carbon Monoxide	—	—	—	—	—	—	
	Methanol	—	—	—	—	—	—	
<b>IIB</b>	Propane	—	—	—	—	—	—	
	Toluene	—	—	—	—	—	—	
	Town Gas (Coal Gas)	Ethylene	—	—	—	—	—	
<b>IIC</b>	Hydrogen	Acetylene	—	—	—	Carbon disulphide	Ethyl nitrate	

(Fig. 1)

The following explanations are about the symbols on the attached Declaration of Conformity.

 CE versions of the IC-F51/F61 which display the “CE” symbol on the serial number label, comply with the essential requirements of the European Radio and Telecommunication Terminal Directive 1999/5/EC, ATEX Directive 94/9/EC and the restriction of the use of certain hazardous substances in electrical and electronic equipment Directive, 2011/65/EU.

 This warning symbol indicates that this equipment operates in non-harmonised frequency bands and/or may be subject to licensing conditions in the country of use. Be sure to check that you have the correct version of this radio or the correct programming of this radio, to comply with national licensing requirement.

• **Country code list (ISO 3166-1)**

	Country	Codes		Country	Codes
1	Austria	AT	18	Liechtenstein	LI
2	Belgium	BE	19	Lithuania	LT
3	Bulgaria	BG	20	Luxembourg	LU
4	Croatia	HR	21	Malta	MT
5	Czech Republic	CZ	22	Netherlands	NL
6	Cyprus	CY	23	Norway	NO
7	Denmark	DK	24	Poland	PL
8	Estonia	EE	25	Portugal	PT
9	Finland	FI	26	Romania	RO
10	France	FR	27	Slovakia	SK
11	Germany	DE	28	Slovenia	SI
12	Greece	GR	29	Spain	ES
13	Hungary	HU	30	Sweden	SE
14	Iceland	IS	31	Switzerland	CH
15	Ireland	IE	32	Turkey	TR
16	Italy	IT	33	United Kingdom	GB
17	Latvia	LV			



**Count on us!**

**< Intended Country of Use >**

AT BE CY CZ DK EE  
FI FR DE GR HU IE  
IT LV LT LU MT NL  
PL PT SK SI ES SE  
GB IS LI NO CH BG  
RO TR HR

A-6365H-1EU-15

Printed in Japan

© 2005–2013 Icom Inc.

Printed on recycled paper with soy ink.

**Icom Inc.**

1-1-32 Kamiminami, Hirano-ku, Osaka 547-0003, Japan